

Manuscript EMBO-2016-95273

## AMPK $\alpha$ 1-LDH pathway regulates muscle stem cell self-renewal by controlling metabolic homeostasis

Marine Theret, Linda Gsaier, Bethany Schaffer, Gaëtan Juban, Sabrina Ben Larbi, Michèle Weiss-Gayet, Laurent Bultot, Collodet Caterina, Marc Foretz, Dominique Desplanches, Pascual Sanz, Zizhao Zang, Lin Yang Guillaume Vial, Benoit Viollet, Kei Sakamoto, Anne Brunet, Bénédicte Chazaud and Rémi Mounier

*Corresponding author: Rémi Mounier, CNRS UMR 5310, INSERM U1217, Université de Lyon*

---

### Review timeline:

Submission date:	18 July 2016
Editorial Decision:	29 August 2016
Revision received:	09 March 2017
Editorial Decision:	07 April 2017
Revision received:	18 April 2017
Accepted:	20 April 2017

---

Editor: Andrea Leibfried

### Transaction Report:

(Note: With the exception of the correction of typographical or spelling errors that could be a source of ambiguity, letters and reports are not edited. The original formatting of letters and referee reports may not be reflected in this compilation.)

---

1st Editorial Decision

29 August 2016

Thank you for submitting your manuscript for consideration by the EMBO Journal. It has now been seen by two referees whose comments are shown below.

As you will see, referee #1 (muscle physiology and metabolism expert) appreciates your study and provides input on how to improve your metabolic data and how to broaden the impact of your results. Referee #2 (stem cell metabolism expert), however, notes that there is no tracing of AMPK $\alpha$ 1 knock-out in your model, and this would be needed to support your conclusions and thus for publication here. Please note that I sought additional feedback from another muscle stem cell expert on the importance of this specific criticism, and this advisor confirmed that the concern about the full population knockout needs to be resolved. Referee #2 furthermore points out that for the metabolic analysis, MuSCs instead of MPCs need to be used to firmly support your claims and that there are currently inconsistencies within your dataset that need to be explained.

Given the interest into the topic, I can offer to consider a revised version of your manuscript, addressing all criticisms of the referees. I should remind you that it is EMBO Journal policy to allow a single round of revision only and that, therefore, acceptance or rejection of the manuscript will depend on the completeness of your responses in this revised version. I do realize that addressing all the referees' criticisms, and especially the ones from referee #2, will require a lot of additional time and effort and be technically challenging. Therefore, please consider your options carefully. Should

you not be able to address the referees' concerns it is in your best interest to seek publication elsewhere. In this case please let us know so we can withdraw your manuscript from our system.

If you decide to thoroughly revise the manuscript for the EMBO Journal, please include a detailed point-by-point response to the referees' comments. Please bear in mind that this will form part of the Review Process File, and will therefore be available online to the community.

-----  
REFEREE COMMENTS

Referee #1:

The work of Theret and co-workers is a well designed and performer work on the role of AMPK1a in Muscle Stem Cell (MuSC) fate. The authors addressed the issue by generating inducible MuSC specific AMPK1a knockout mice. The data clearly support the evidence of an AMPK-dependent effect. Further experiments in vivo and in vitro linked AMPK to MuSC self renewal. Mechanistic insight revealed a direct link between AMPK and glucose homeostasis and identified the enzyme LDH as the critical factor for MuSC fate. The data are of interest for the mycology and stem cell communities. Experiments are elegant and properly designed to address authors' questions. Few minor points should be addressed to improve the already high quality of the present paper.

Point1. Figure 2B-D. These data are important for therapeutic purpose in muscle dystrophies. The authors performed experiments on TA muscle. It would be important to know whether this effect is shared among different muscles with different metabolism. Authors should check whether gastrocnemius and soleus muscles of AMPK1 KO do show the same decrease of muscle mass after CTX injection when compared to controls.

Moreover, since the effect on muscle mass is still present after 1 month from muscle injury, it would be critical to monitor whether any change of fiber type occurred that would explain the decrease of muscle mass. Authors should quantify the percentage of beta oxidative versus glycolytic fibers as well as MHC2A versus MHC2B/2X fibers.

Point 2. Figure 4E. The decrease of PGC1a/b is not sufficient to claim that mitochondrial biogenesis is impaired since other factors may compensate the reduced transcript level, including post-translational modifications. Authors must monitor mitochondrial mass by western blot analyses for mitochondrial proteins.

Point 3. Figure 4G. It would be interesting to have also the Pax7+ Ki67/MyoD- cells in normal culture condition to show that LG and HGP induce an increase of MuSC self renewal in WT cells to level of AMPK1aKO and that LG and HGP do not further increase the Pax7+ Ki67/MyoD- cells in AMPK1aKO

Referee #2:

Theret and colleagues examine the role for AMPK regulation of metabolism in MuSC fate. They show that AMPKa1 KO MuSCs have increased quiescent self-renewing cells with differentiation in vitro, and in vivo this impairs muscle regeneration from cardiotoxin (CTX) injury. AMPKa1 KO MuSCs also show increased glycolysis, and LDH overexpression replicates the phenotype of AMPKa1 KO MuSCs, with increased quiescent self-renewing cells and elevated glycolysis.

1. The authors discuss a recent study (Fu et al. 2015) in which AMPKa1 is also deleted in MuSCs but suggest that study was potentially flawed since floxed Exon 3 may not be sufficient to delete AMPKa1 but instead could result in a truncated, still functional version of the protein. However, these floxed mice were generated by the Morrison lab (Nakada, et al Nature 2010) and showed reduced AMPKa1 expression and reduced T172 phosphorylation in a hematopoietic stem cell deleter strain that demonstrated an AMPKa1-dependent phenotype. Also, immunoblots in Fu et al. 2015 (their Figure 2) show an incomplete deletion of AMPKa1 in MuSCs with the residual protein

band remaining at the same, untruncated size. These prior publications argue against the claim and study motivation that exon 3 deleted AMPK $\alpha$ 1 mice in MuSCs has not been evaluated before or could somehow remain functional and truncated, which affects the novelty and impact of the current study.

2. Continuing on point 1 above, Theret et al. do not show how their floxed AMPK $\alpha$ 1 mice are generated (they reference Miller et al JCI 2011 in the supplement but details of the mouse are not provided therein) nor do they provide a western blot of their AMPK $\alpha$ 1 KO MuSCs, to exclude the same criticism leveled at Fu et al in their own work. Furthermore, Figure S1E shows that the authors' MuSCs retain a significant amount of the non-deleted AMPK $\alpha$ 1 with tamoxifen injections, and they do not tag the cells with a lox-stop-lox traceable reporter (e.g. YFP) to identify/track those MuSCs that lack AMPK $\alpha$ 1 and therefore have not rigorously demonstrated the importance or lack of importance of the remaining AMPK in these cells in their own work.

3. Figure 1G shows that the number of activated PAX7+ Ki67/MyoD+ cells are similar between AMPK $\alpha$ 1 KO and WT MuSCs, and the Pax7- Ki67/MyoD+ differentiating cells are even less in the KO versus WT MuSCs, yet Figures 2F and 2G show an elevated proliferation rate in the AMPK $\alpha$ 1 KO versus WT MuSCs. How is this possible? Since by definition the quiescent MuSCs and terminally differentiated cells will be non-proliferative, and there is a larger percentage of activated and differentiating cells present in the WT versus KO MuSCs, these findings appear contradictory, and the sustaining macrophages have been excluded as a source of Edu uptake.

4. Text bottom page 9 - HSA- $\alpha$ 1 KO mice reference to Figures 2A-D should be Figures 3A-D. Also, Figure 3 is negative data that provides an important control for the cell population in the study but could be presented as a supplemental rather than main figure.

5. Figure 4A and associated text on top of page 11- It is not established that levels of PKM1/2 isoforms are a suggestive readout for glycolysis or oxidative phosphorylation- this negates translation, post-translational modifications, degradation, and other forms of regulation beyond gene expression. The extracellular acidification rate (ECAR) can be obtained using the methods employed to obtain OCR and provided a better and more accepted estimate of glycolytic pathway activity and should parallel measured differences in lactate levels provided in Figure 4B.

6. Figure 4C- arrows indicating when oligomycin and CCCP (x3) were injected should be shown for OCR studies.

7. Figure 4- mitochondrial mass should be established between WT and AMPK $\alpha$ 1 KO MPCs to validate the suggestion that mitochondrial biogenesis differences cause less electron transfer with CCCP uncoupling- the expression of PGC1 $\alpha$  and PGC1 $\beta$  mRNAs is insufficient evidence of such a difference. Furthermore, even with or without mitochondrial mass differences between cells, other differences in electron transport chain assembly or electron transfer to terminal electron acceptors could be similar or different between WT and KO MPCs, accounting for the change in maximal respiration capacity observed in Figure 4C. Nothing has been directly established to indicate the source of this difference in the studies provided thus far.

8. Figure 4F-H- to inhibit OxPhos and force cells to utilize glycolysis, the HG and LG conditions should include and be compared with an OxPhos inhibitor to strengthen the argument that glycolysis drives self-renewal, as the conditions used still allow for glucose to be shuttled into OxPhos and TCA cycle pathways unabated.

9. Figure S4F- MuSCs do not show a significant difference in lactate production with AMPK $\alpha$ 1 KO in contrast to a statistical difference in lactate production for MPCs (Figure 4B). Although MPCs are used because more cells can be obtained than MuSCs, their metabolic patterns and requirements may differ and, therefore, MPCs may not be a good surrogate for MuSC glycolysis dependence in these studies.

10. Figure 4G- A significant reduction in the number of Pax7+Ki67/MyoD- quiescent MuSCs is observed when WT MuSC are grown in galactose compared to low glucose, but this is not statistically significant compared to high glucose culture conditions, and there is no effect of these carbon sources for AMPK $\alpha$ 1 KO MuSCs. These results suggest possible differential activation of

AMPK in WT MuSCs cultured in galactose versus two different concentrations of glucose and should be verified. Also, the lack of statistical difference in Pax7+Ki67/MyoD- positive nuclei in AMPK $\alpha$ 1 KO versus WT MuSCs in high glucose media (25mM) is a different result from Figure 1B, where cells were grown in DMEMF12 media with a comparably high glucose concentration (17.5mM). What is the basis for the discordance in these results?

11. Figure 5G- the effect of compound 991 on LDHA activity in MuSCs at the doses indicated should be determined.
12. Figure 6B- A WT control should be included with similar sodium oxamate dosing.
13. Evidence for a "return to quiescence" described in the Discussion section is lacking. To make this claim, one would have to label MuSCs as they become activated, and then trace them to determine whether there are differences in returning to a quiescent MuSC or differentiation. The text should be changed to reflect this.
14. Evidence that AMPK fosters self-renewal is also lacking as there are no cell tracing studies for self-renewal, only that there are increased Pax7+ MuSCs that have a slightly higher uptake of EdU. The language should be changed, or Pax7+ MuSCs should be tracked to assess their stemness and self-renewing capacity.

We thank the editor and the experts for their constructive comments. They helped us to significantly improve the comprehension of our manuscript. We have performed several new experiments and addressed reviewers' concerns and hope the revised manuscript is now acceptable for publication.

**Referee #1:**

The work of Theret and co-workers is a well designed and performer work on the role of AMPK1a in Muscle Stem Cell (MuSC) fate. The authors addressed the issue by generating inducible MuSC specific AMPK1a knockout mice. The data clearly support the evidence of an AMPK-dependent effect. Further experiments in vivo and in vitro linked AMPK to MuSC self renewal. Mechanistic insight revealed a direct link between AMPK and glucose homeostasis and identified the enzyme LDH as the critical factor for MuSC fate. The data are of interest for the mycology and stem cell communities. Experiments are elegant and properly designed to address authors' questions. Few minor points would should be addressed to improve the already high quality of the present paper.

We thank the referee #1 for his/her positive comments regarding the quality, the interest, the novelty and the mechanistic insight of our work. We have addressed all the comments/points raised by the referee to further improve the quality of our manuscript.

Point 1a. Figure 2B-D. These data are important for therapeutic purpose in muscle dystrophies. The authors performed experiments on TA muscle. It would be important to know whether this effect is shared among different muscles with different metabolism. Authors should check whether gastrocnemius and soleus muscles of AMPK1 KO do show the same decrease of muscle mass after CTX injection when compared to controls.

Because *soleus* muscle is a small muscle ( $6.6 \pm 2.1$  mg (Charles, Cappellari et al., 2016)) and is located between *plantaris* and *gastrocnemius* (GAS) muscles, accurate CTX injection in the *soleus* muscle is technically difficult and poorly reproducible. Thus, we have injected CTX in GAS muscles and measured the weight of these

muscles 28 days after CTX injury in Pax7- $\alpha$ 1<sup>+/+</sup> and Pax7- $\alpha$ 1<sup>-/-</sup> mice. There was a significant reduction of GAS muscle mass (Figure S2A, -18.8%, p<0.01, n=4) of Pax7- $\alpha$ 1<sup>-/-</sup> mice as compared with Pax7- $\alpha$ 1<sup>+/+</sup> mice, similarly as observed for TA muscles (Figure 2D -18.8%, p<0.001, n=8). These results show that impairment of skeletal muscle regeneration in the absence of AMPK $\alpha$ 1 in MuSCs is not limited to a particular muscle type.

**Point 1b. Moreover, since the effect on muscle mass is still present after 1 month from muscle injury, it would be critical to monitor whether any change of fiber type occurred that would explain the decrease of muscle mass. Authors should quantify the percentage of beta oxidative versus glycolytic fibers as well as MHC2A versus MHC2B/2X fibers.**

As requested by the reviewer, muscle fiber type has been monitored by quantifying MHCI and MHCIIA positive fibers in TA of Pax7- $\alpha$ 1<sup>+/+</sup> and Pax7- $\alpha$ 1<sup>-/-</sup> mice before (Day 0) and 28 days after injury (Day 28). No difference was observed between TA muscles of Pax7- $\alpha$ 1<sup>+/+</sup> and Pax7- $\alpha$ 1<sup>-/-</sup> mice for both MHCI and MHCIIA, before and after injury (see below Figure 1). These results suggest that the decreased muscle mass observed in Pax7- $\alpha$ 1<sup>-/-</sup> cannot be explained by changes of fiber type.

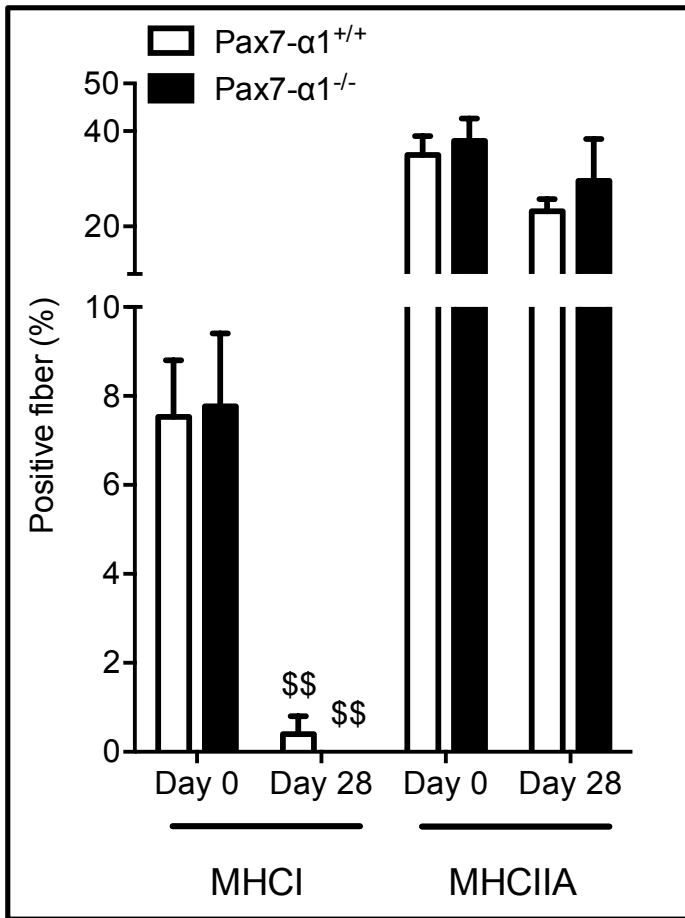

**Figure 1:** Percentage of fibers positive for MHCI and MHCIIA in TA muscles of Pax7-α1<sup>+/+</sup> and Pax7-α1<sup>-/-</sup> mice before (Day 0) and 28 days after CTX injury (Day 28). Data are means ± SEM from at least 3 animals. Day 28 vs. Day 0: \$\$, p<0.01.

**Point 2. Figure 4E.** The decrease of PGC1a/b is not sufficient to claim that mitochondrial biogenesis is impaired since other factors may compensate the reduced transcript level, including post-translational modifications. Authors must monitor mitochondrial mass by western blot analyses for mitochondrial proteins.

To answer referee's request, we measured mitochondrial mass and activity using 2 different readouts:

1) It has been shown that Citrate Synthase (CS) activity, a critical enzyme of Krebs Cycle (Nichenko, Southern et al., 2016), is significantly lower in skeletal muscles of

PGC1 $\alpha$  KO mice as compared with WT mice (Leick, Lyngby et al., 2010). In order to confirm an impairment of mitochondrial biogenesis suggested by the decrease of PGC1 $\alpha/\beta$ , we measured CS activity (Garnier, Fortin et al., 2003, Kristensen, Skov et al., 2014) in MPCs. Consistent with our hypothesis, a significant decrease in CS activity was observed in the absence of AMPK $\alpha$ 1 in MPCs (Figure 3F, -31.8%,  $p < 0.001$ ,  $n = 4$ ).

2) TOM22 protein is a core component of the mitochondrial outer membrane translocase and is used as a readout for mitochondrial mass (Latil, Rocheteau et al., 2012). A significant decrease of the number of MPCs positive for this marker was observed in AMPK $\alpha$ 1 KO MPCs as compared with WT MPCs (Figure S3G, -11%,  $p < 0.03$ ,  $n = 6$ ), demonstrating that mitochondrial mass was altered in the absence of AMPK $\alpha$ 1.

**Point 3. Figure 4G.** It would be interesting to have also the Pax7<sup>+</sup> Ki67/MyoD<sup>-</sup> cells in normal culture condition to show that LG and HGP induce an increase of MuSC self renewal in WT cells to level of AMPK1aKO and that LG and HGP do not further increase the Pax7<sup>+</sup> Ki67/MyoD<sup>-</sup> cells in AMPK1aKO.

From our point of view, it is difficult to finely investigate the role of glucose concentrations on MuSC fate. Indeed, testing high concentration of glucose (25 mM) without pyruvate is not possible since this condition is toxic for MuSCs and induces death of the cells (data not shown). In any case, we also performed experiments using the OxPhos inhibitor oligomycin. Oligomycin also induced a high level of apoptosis in MuSC culture after 48h (see Figure 2 below), even at low doses (*i.e.* less than 1  $\mu\text{g/ml}$ ), preventing any analysis of MuSC self-renewal. These data however demonstrate the crucial role of OxPhos pathway in MuSC survival.



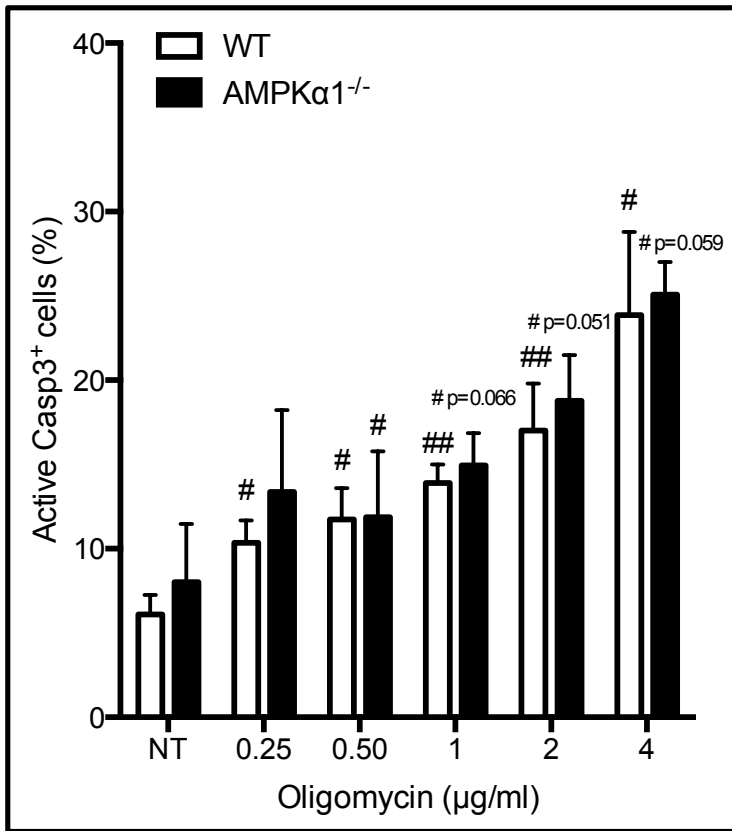

**Figure 2: Effect of OxPhos inhibitor of MuSC viability.** MuSCs were extracted from total hindlimb muscles and active Caspase 3 labeling was performed after 48 h of culture in differentiation condition under oligomycin stimulation. #p<0.05, ##p<0.01 versus NT.

## Referee #2:

Theret and colleagues examine the role for AMPK regulation of metabolism in MuSC fate. They show that AMPKa1 KO MuSCs have increased quiescent self-renewing cells with differentiation in vitro, and in vivo this impairs muscle regeneration from cardiotoxin (CTX) injury. AMPKa1 KO MuSCs also show increased glycolysis, and LDH overexpression replicates the phenotype of AMPKa1 KO MuSCs, with increased quiescent self-renewing cells and elevated glycolysis.

1. The authors discuss a recent study (Fu et al. 2015) in which AMPKa1 is also deleted in MuSCs but suggest that study was potentially flawed since floxed Exon 3 may not be sufficient to delete AMPKa1 but instead could result in a truncated, still functional version of the protein. However, these floxed mice were generated by the Morrison lab (Nakada, et al Nature 2010) and showed reduced AMPKa1 expression and reduced T172 phosphorylation in a hematopoietic stem cell deleter strain that demonstrated an AMPKa1-dependent phenotype. Also, immunoblots in Fu et al. 2015 (their Figure 2) show an incomplete deletion of AMPKa1 in MuSCs with the residual protein band remaining at the same, untruncated size. These prior publications argue against the claim and study motivation that exon 3 deleted AMPKa1 mice in MuSCs has not been evaluated before or could somehow remain functional and truncated, which affects the novelty and impact of the current study.

The conditional AMPK alpha1 KO model used in our study relies on the deletion of both exons 4 and 5 (see below Figure 3, (Miller, Chu et al., 2011); allele Prkaa1tm1.1Mfor; <http://www.informatics.jax.org/allele/MGI:5527231>). Since the deletion of exon 4 and 5 removes about one third of the catalytic kinase domain, including the phosphorylation site T172 involved in AMPK activation, this deletion is not compatible with the production of any AMPKalpha1 protein displaying kinase activity.

In contrast, the conditional model used in Fu's study (Fu, Zhu et al., 2015) relies on the deletion of exon3 only ((Nakada, Saunders et al., 2010); allele Prkaa1tm1.1Sjm <http://www.informatics.jax.org/allele/MGI:4836199>). Several arguments strongly suggest that AMPKalpha1 gene harboring deletion of exon3 might be able to generate

shorter AMPKalpha1 protein with intact kinase activity:

(i) the natural occurrence of exon3 skipping by direct splicing of exon2 to exon4 on AMPKa1 transcripts is attested by several mouse EST recorded in UCSC genome browser (BY123356, BY194044, BY209625, BY50654, CB245065 listed on <https://genome.ucsc.edu/>). Moreover, RNA-seq data indicate that the frequency of exon3 skipping can reach up to 5-8% that of exon3 inclusion in Mouse T cells (alternate splicing events recorded in Immunological Genome Project website; <https://www.immgen.org/>),

(ii) in Fu's study, a significant amount of the AMPKalpha1 protein is still detectable (>25% as we could roughly estimate by densitometry tracing of WB shown in Fig 2D in Fu et al, JBC 2015, 290: 2644-2656) despite less than 0.1% of remaining undeleted transcripts (Fig 2C). This remaining amount of AMPKalpha1 protein observed after exon3 deletion in AMPKa1 gene has been attributed to AMPKalpha2 protein but, to our knowledge, this interpretation has never been firmly established using alpha1 or alpha 2 specific antibodies. Finally, in Figure 2 of Fu et al. (2015), the deletion of AMPK $\alpha$ 1 is visible in the western blot of non-myogenic cells (Panel D), while in myogenic cells (Panel E) the bands for AMPKa1 and its phosphorylated form are present.

Finally, unlike in Fu et al. (2015) study, all our *in vitro* and *ex vivo* experiments were performed with cells isolated from total body AMPK $\alpha$ 1<sup>-/-</sup> mouse strain, excluding the impact of an inadequate deletion of AMPK $\alpha$ 1 in these experiments.

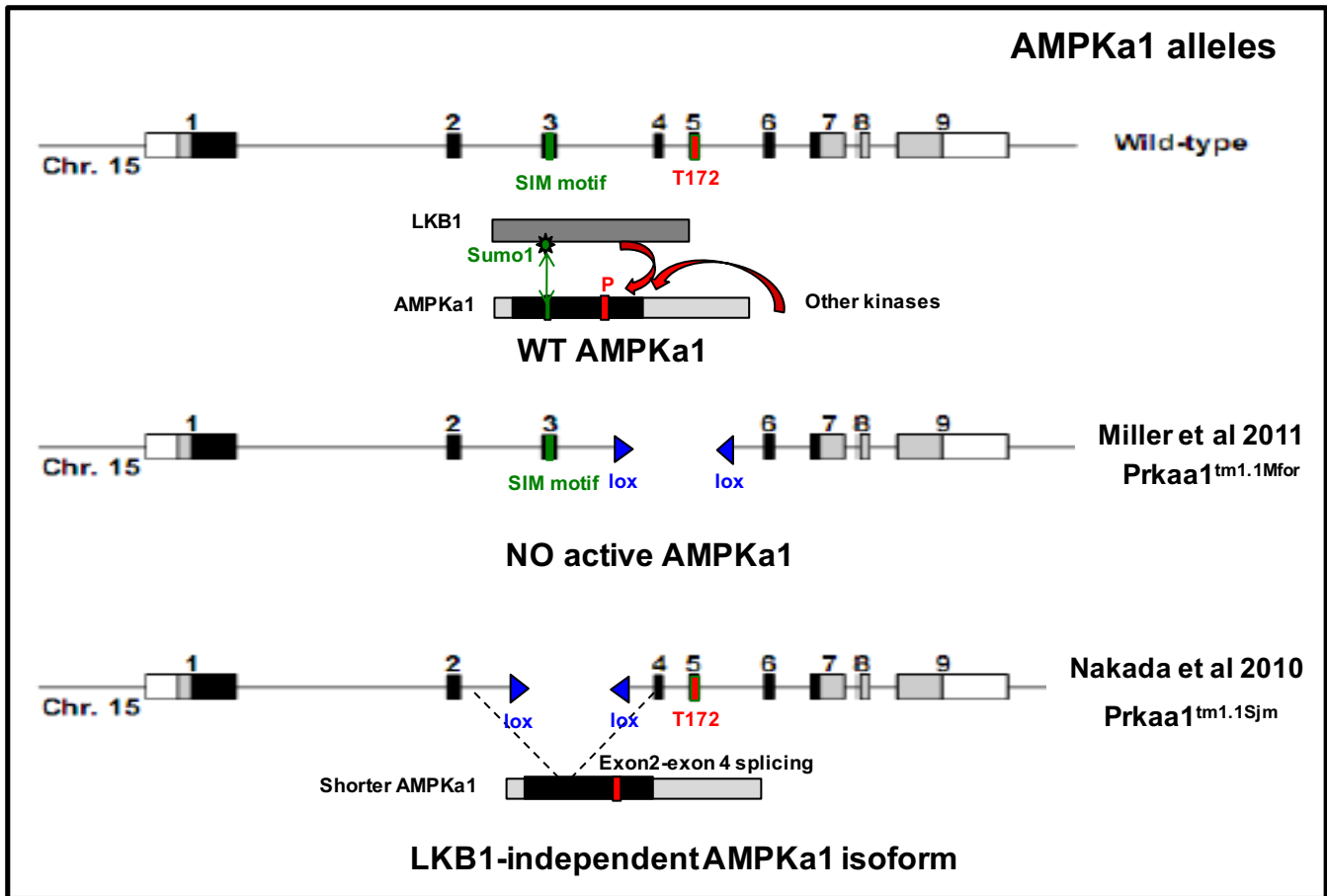
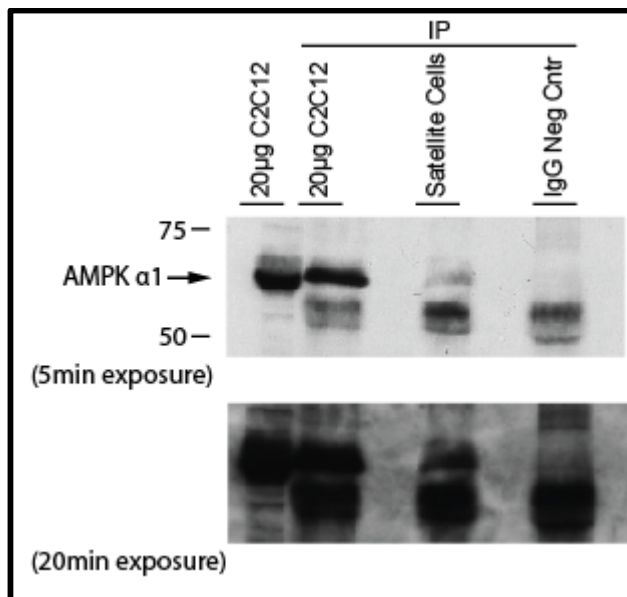

**Figure 3:** Structure of WT, floxed exon3 and exon4/5 alleles and corresponding predicted proteins.

2. Continuing on point 1 above, Theret et al. do not show how their floxed AMPKa1 mice are generated (they reference Miller et al JCI 2011 in the supplement but details of the mouse are not provided therein) nor do they provide a western blot of their AMPKa1 KO MuSCs, to exclude the same criticism leveled at Fu et al in their own work.

The reviewer's point is valid and it would be informative to accurately quantify and demonstrate the level of AMPK $\alpha$ 1/prkaa1 deletion in Pax7- $\alpha$ 1<sup>-/-</sup> MuSCs by Western blot analysis. For this purpose, we purified MuSCs by FACS as described in the Methods and we obtained approximately ~100,000 cells (pooled from 3 wild-type mice after a 3-hour cell sorting session, MuSC cell sorting must be done under a slow flow to preserve their viability and to guarantee their purity). We decided to not increase the number of mice to obtain a higher number of MuSCs because the duration of sorting

would have been drastically increased (e.g. a 6-hour cell sorting session for 6 mice), compromising the quality of the samples obtained when cells stayed more than 3 hours on ice. MuSCs were lysed by adding 100  $\mu$ l of lysis buffer and 1/5 (20  $\mu$ l) of the total lysates was used for Western blot analysis. This resulted in no detectable signal for AMPK $\alpha$ 1 even with long exposure (data not shown). To maximize detection of AMPK $\alpha$ 1, we next performed Western blotting of AMPK $\alpha$ 1 following its immunoprecipitation (IP) using the entire protein extracts from ~100,000 MuSCs (wild-type). We used lysates from C2C12 undifferentiated/myoblast cells (that predominantly express AMPK $\alpha$ 1, as MuSCs) as a positive control. As illustrated below (see Figure 4), we detected a clear and robust signal of AMPK $\alpha$ 1 protein from 20  $\mu$ g of C2C12 lysates, while we could only detect very faint band from the MuSCs lysates. We could enhance the signal intensity of MuSC AMPK $\alpha$ 1 by exposing the film much longer (20min), but there was an increase of the level of background and non-specific bands (see IgG negative control lane). Based on these results, we concluded that it is not possible to accurately quantify AMPK $\alpha$ 1 and robustly assess deletion efficiency of *prkaa1* in the KO animals from MuSCs even using 3 animals.



**Figure 4: AMPK $\alpha$ 1/*prkaa1* deletion in muscle cells by Western blot analysis**

As requested, we added the detail for the construction of the AMPK $\alpha$ 1 floxed strain in the Figure 5 below. A manuscript describing this model will be submitted in the near future by Marc Foretz and Benoit Viollet. Of note, this strain has been successfully used to deplete AMPK $\alpha$ 1 in myeloid cells in a previous study (Mounier, Theret et al., 2013), indicating its efficiency.

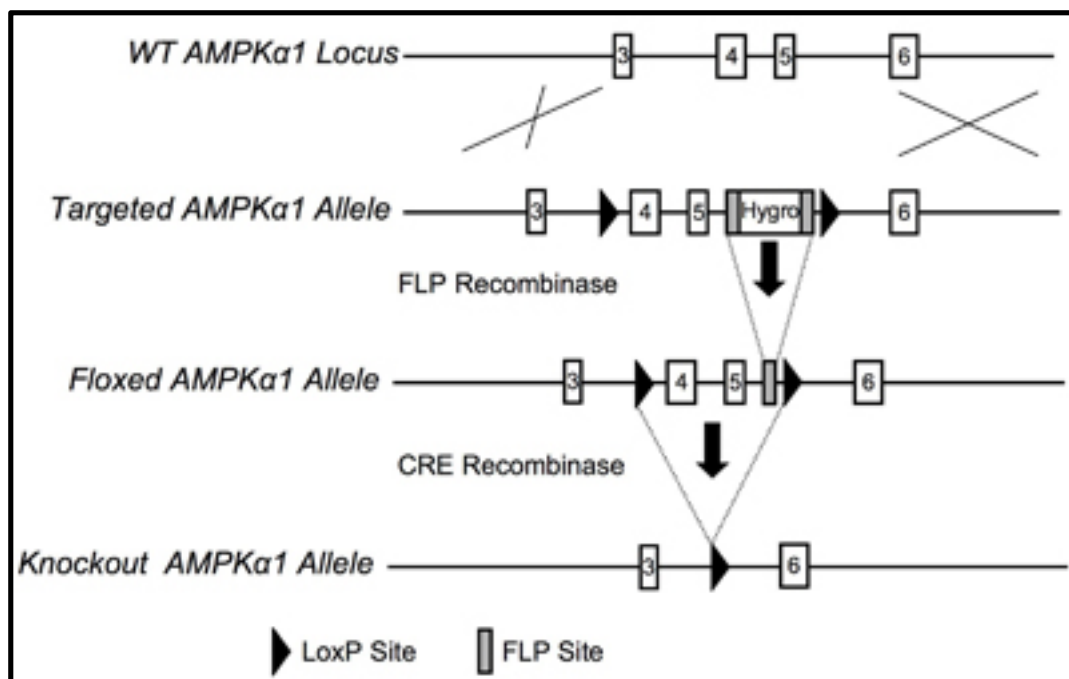

**Figure 5: Generation of knockout of the catalytic  $\alpha$ 1 subunit of AMPK.** Diagram of the generation of AMPK $\alpha$ 1 knockout. Structure of the AMPK $\alpha$ 1 locus with the targeted allele are shown. Numbered boxes indicate exons. Exons 4 to 5 were flanked by loxP sites. A hygromycin resistance cassette flanked by FRT sites was inserted upstream from the 3' loxP site. Hygromycin resistance cassette was excised by the expression of the FLP recombinase *in vivo*. Disruption of exons 4 to 5 flanked by loxP sites was achieved by crossing AMPK $\alpha$ 1lox/lox mice with mice expressing cre recombinase.

Point 2 continued: Furthermore, Figure S1E shows that the authors' MuSCs retain a significant amount of the non-deleted AMPK $\alpha$ 1 with tamoxifen injections, and they do not tag the cells with a lox-stop-lox traceable reporter (e.g. YFP) to identify/track those MuSCs that lack AMPK $\alpha$ 1 and therefore have not rigorously demonstrated the importance or lack of importance of the remaining AMPK in these cells in their own work.

Tagging the cells with a lox-stop-lox traceable reporter to identify/track MuSCs that lack AMPK $\alpha$ 1 will require the construction of a new mouse model, which is not possible within the time frame of the revision process. To our knowledge, no laboratories working on MuSCs have used an adequate traceable reporter for the analysis of the deletion of a gene of interest. The Pax7<sup>CRE-ERT2</sup> mouse strain we used in this study contains a DS-Red sequence with the CRE cassette replacing Pax7 allele. However, the original description of the strain reported that IRES-DsRed fluorescence is not detectable by FACs or epifluorescence or immunostaining ([www.jax.org/strain/012476](http://www.jax.org/strain/012476)) (Lepper, Conway et al., 2009). Moreover, we respectfully disagree with the referee concerning the fact that "*a tagged cells with a lox-stop-lox traceable reporter (e.g. YFP) will identify/track those MuSCs that lack AMPK $\alpha$ 1*". Indeed, because the Lox-Stop-Lox-YFP (such as in Rosa26 mouse) chromatin environment is completely different from the LoxP sites on the target gene, it is highly likely that the accessibility of the CRE to these two sites will be different, and thus the efficiency of the CRE to recombine will be also different. Thus, this kind of reporter only allows to trace the cells in which the CRE is expressed, but does not guarantee its efficiency of recombination at the target site. That strategy was used in Fu et al., 2015, and allowed to determine if the CRE was expressed in MuSCs, but it did not quantify the deletion of the gene of interest, *ampka1* in this case.

Nevertheless, we confirmed the efficiency of AMPK/prkaa1 deletion in MuSCs in our model. We added in Figure S1E the control of the deletion of AMPK $\alpha$ 1 in MuSCs (Sca1/CD31/CD45<sup>-</sup> $\alpha$ 7int/CD34<sup>+</sup>) 28 days after CTX injury. AMPK $\alpha$ 1 deletion was total in MuSCs from Pax7- $\alpha$ 1<sup>-/-</sup> mice demonstrating that the deletion at the DNA level was univocal and definitive after tamoxifen treatment, and showing that no escapers were present in our *in vivo* experiments. Please see the Figure S1E.

Finally, we rephrased the statement regarding the study of Fu et al. (2015). Please see the modifications in the Introduction (Page 6, first paragraph).

As a whole, in our study, *in vitro* experiments have been all performed using total AMPK KO cells and *in vivo* experiments were performed using animals in which a high reduction of total genomic deletion of *prkaa1* was specifically observed in MuSCs.

3. Figures 1G shows that the number of activated PAX7+Ki67/MyoD+ cells are similar between AMPKa1 KO and WT MuSCs, and the Pax7- Ki67/MyoD+ differentiating cells are even less in the KO versus WT MuSCs, yet Figures 2F and 2G show an elevated proliferation rate in the AMPKa1 KO versus WT MuSCs. How is this possible? Since by definition the quiescent MuSCs and terminally differentiated cells will be non-proliferative, and there is a larger percentage of activated and differentiating cells present in the WT versus KO MuSCs, these findings appear contradictory, and the sustaining macrophages have been excluded as a source of Edu uptake.

The two results are not comparable since they have been generated at different time points after injury. Figure 1G represents the proportion of quiescent MuSCs (Pax7<sup>+</sup>Ki67/MyoD<sup>-</sup>), activated MuSCs (Pax7<sup>+</sup>Ki67/MyoD<sup>+</sup>) and differentiated myogenic cells (Pax7<sup>-</sup>Ki67/MyoD<sup>+</sup>) *in vivo* (i.e. in the skeletal muscle tissue) 28 days after injury, thus at the end of the regeneration process. Figures 2F and 2G represent proliferating MuSCs (CD45/CD31/Sca1<sup>-</sup>α7<sup>+</sup>/Edu<sup>+</sup>) *in vivo* during the early phases of regeneration (between 1 and 6 days after injury) and the number of MuSCs/mg of muscle 6 days after injury, respectively.

4. Text bottom page 9 - HSA-a1 KO mice reference to Figures 2A-D should be Figures 3A-D. Also, Figure 3 is negative data that provides an important control for the cell population in the study but could be presented as a supplemental rather than main figure.

We have made the modifications accordingly and move Figures 3A-D to Figures S2D-G. Please see Figure S2.

5. Figure 4A and associated text on top of page 11- It is not established that levels of PKM1/2 isoforms are a suggestive readout for glycolysis or oxidative phosphorylation- this negates translation, post-translational modifications, degradation, and other forms of regulation beyond gene expression. The extracellular acidification rate (ECAR) can be obtained using the methods employed to obtain OCR and provided a better and



more accepted estimate of glycolytic pathway activity and should parallel measured differences in lactate levels provided in Figure 4B.

We respectfully disagree with the referee. It has recently been reported that PKM1 and PKM2 expression are robust readouts for glycolysis and OxPhos in MuSCs (Ryall, Dell'Orso et al., 2015) and in cancer cells (Dayton, Jacks et al., 2016). Moreover, we have measured LDH activity and lactate concentration, which are two major outcomes of the glycolytic pathway. Indeed, as LDH converts pyruvate into lactate, this enzyme is a defined regulator of aerobic glycolysis *versus* oxidative phosphorylation.

ECAR, an indirect readout of glycolysis, is measured essentially through the modification of the pH ( $\Delta$ pH) in the medium of the cell culture. However, other metabolic processes in cells, such as CO<sub>2</sub> production by the TCA cycle, may affect the pH of the media, complicating the interpretation of this analysis (TeSlaa & Teitell, 2014). In addition, bicarbonate and media pH can also play a role in regulating glycolysis, which can confound measurements of ECAR (TeSlaa & Teitell, 2014). We did not observe modification of ECAR in basal condition in WT *versus* AMPK $\alpha$ 1 KO MPCs in our conditions (please see Figure S3F). Apart the above explanation, the difference of culture conditions that are required for Seahorse experiments (6 hours with no serum) and for lactate concentration/LDH activity experiments (24 hours with 2% horse serum) may explain the discrepancy between ECAR and lactate concentration in our study. Such a discrepancy between these two measurements has already been documented in aged MuSCs (Zhang, Ryu et al., 2016).

**6. Figure 4C- arrows indicating when oligomycin and CCCP (x3) were injected should be shown for OCR studies.**

We have made the requested modification by representing the injections as vertical dotted lines. Please see Figure 3C.

**7. Figure 4- mitochondrial mass should be established between WT and AMPKa1 KO**

MPCs to validate the suggestion that mitochondrial biogenesis differences cause less electron transfer with CCCP uncoupling- the expression of PGC1a and PGC1b mRNAs is insufficient evidence of such a difference. Furthermore, even with or without mitochondrial mass differences between cells, other differences in electron transport chain assembly or electron transfer to terminal electron acceptors could be similar or different between WT and KO MPCs, accounting for the change in maximal respiration capacity observed in Figure 4C. Nothing has been directly established to indicate the source of this difference in the studies provided thus far.

To answer referee's request, we measured mitochondrial mass and activity using 2 different readouts:

1) It has been shown that Citrate Synthase (CS) activity, a critical enzyme of Krebs Cycle (Nichenko et al., 2016), is significantly lower in skeletal muscles of PGC1 $\alpha$  KO mice as compared with WT mice (Leick et al., 2010). In order to confirm an impairment of mitochondrial biogenesis suggested by the decrease of PGC1 $\alpha/\beta$ , we measured CS activity (Garnier et al., 2003, Kristensen et al., 2014) in MPCs. Consistent with our hypothesis, a significant decrease in CS activity was observed in the absence of AMPK $\alpha$ 1 in MPCs (Figure 3F, -31.8%, p<0.001, n=4).

2) TOM22 protein is a core component of the mitochondrial outer membrane translocase and is used as a readout for mitochondrial mass (Latil et al., 2012). A significant decrease of the number of MPCs positive for this marker was observed in AMPK $\alpha$ 1 KO MPCs as compared with WT MPCs (Figure S3G, -11%, p<0.03, n=6), demonstrating that mitochondrial mass was altered in the absence of AMPK $\alpha$ 1.

Please see Figures 3F and S3G and modifications in the text (pages 11-12).

8. Figure 4F-H- to inhibit OxPhos and force cells to utilize glycolysis, the HG and LG conditions should include and be compared with an OxPhos inhibitor to strengthen the argument that glycolysis drives self-renewal, as the conditions used still allow for glucose to be shuttled into OxPhos and TCA cycle pathways unabated.

As requested, we performed experiments using the OxPhos inhibitor oligomycin. However, it induced high level of apoptosis in MuSC culture after 48h (see below Figure 6), showing the crucial role of this metabolic pathway in MuSC survival. Therefore, it was not possible to analyze MuSC self-renewal under these conditions. Of note, MuSC apoptosis was effective from low doses of oligomycin (*i.e.* less than 1  $\mu\text{g}/\text{mL}$ ), showing that an incomplete inhibition of OxPhos still caused MuSC death.

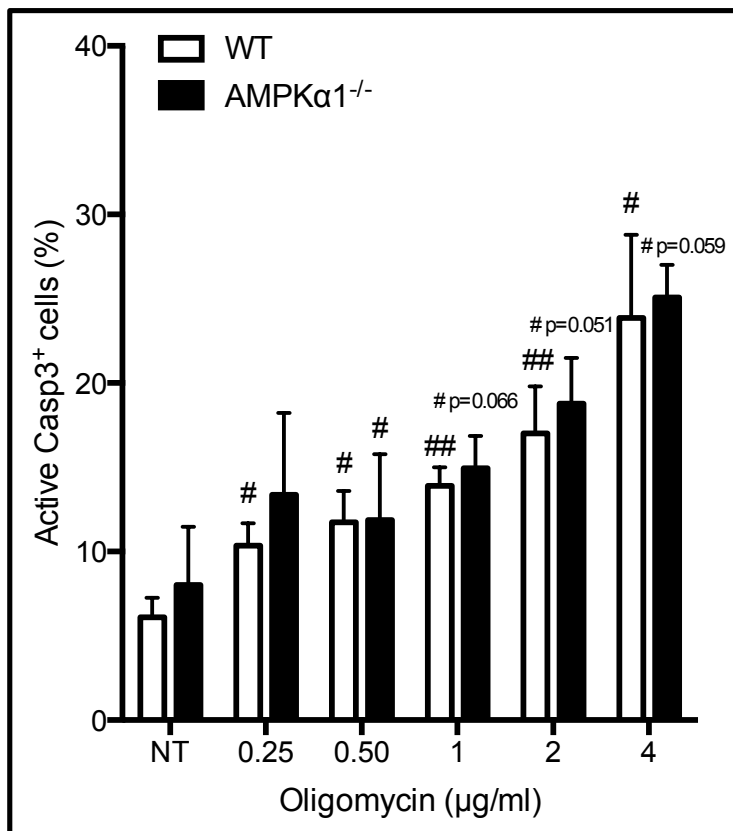

**Figure 6:** Effect of OxPhos inhibitor of MuSC viability. MuSCs were extracted from total hindlimb muscles and active Caspase 3 labeling was performed after 48 h of culture in differentiation conditions under oligomycin stimulation. # $p < 0.05$ , ## $p < 0.01$  versus NT.

9. Figure S4F- MuSCs do not show a significant difference in lactate production with AMPK $\alpha$ 1 KO in contrast to a statistical difference in lactate production for MPCs (Figure 4B). Although MPCs are used because more cells can be obtained than MuSCs, their metabolic patterns and requirements may differ and, therefore, MPCs may not be

a good surrogate for MuSC glycolysis dependence in these studies.

These two measurements of lactate concentration in medium of non-activated (*i.e.* basal conditions) WT and AMPK $\alpha$ 1 KO cells have been performed in different conditions for different purposes. On one hand, lactate concentration was measured in medium of MPCs (Figure 3B) in the same culture conditions as for all other metabolic measurements requiring high amounts of cells (*pkm* and *pgc* expression, citrate synthase, LDH and PK activities, 2-NBDG, TOM 22). On the other hand, lactate concentration in medium of MuSCs (Figure S3H) was measured to assess the efficiency of galactose treatment on glycolysis as compared with low (5 mM glucose) or high (25 mM glucose and 1 mM pyruvate) glucose treatments (Figure 3H), under completely different culture conditions made necessary by the low number of cells recovered after cell sorting. Indeed, MuSCs were cultured in matrigel-coated plates at 30 000 cells/cm<sup>2</sup> in 48 well-plates (*i.e.* 22 500 cells *per well*) for 48 hours in DMEM with various glucose concentrations (Figure S3H), while MPCs were cultured in gelatin-coated plates at 60 000 cells/cm<sup>2</sup> in 6 well-plates (*i.e.* 600 000 cells *per well*) for 24 hours in DMEM-HAMF12 (17.5 mM glucose and 1mM pyruvate) (Figure 3B). Finally, the composition of the media for MPC culture (DMEM-HAMF12, #31331-028, GIBCO) is quite different from the composition of the media used in HGP condition of MuSCs (DMEM, #11966-025 GIBCO), notably regarding amino acid quantities (please see the table in response of comment #10 below for some examples).

Thus, although there are some differences, driven notably by cell culture conditions, MPCs have been shown to share the main myogenic features with MuSCs, including high activation rate after seeding (Olguin & Olwin, 2004) and return to quiescence under differentiation conditions (Abou-Khalil, Le Grand et al., 2013). Because, they can provide large number of cells, MPCs are indispensable for metabolic experiments.

**10. Figure 4G- A significant reduction in the number of Pax7+Ki67/MyoD- quiescent MuSCs is observed when WT MuSC are grown in galactose compared to low glucose, but this is not statistically significant compared to high glucose culture conditions, and there is no effect of these carbon sources for AMPKa1 KO MuSCs. These results**

suggest possible differential activation of AMPK in WT MuSCs cultured in galactose versus two different concentrations of glucose and should be verified. Also, the lack of statistical difference in Pax7<sup>+</sup>Ki67/MyoD<sup>-</sup> positive nuclei in AMPK $\alpha$ 1 KO versus WT MuSCs in high glucose media (25mM) is a different result from Figure 1B, where cells were grown in DMEMF12 media with a comparably high glucose concentration (17.5mM). What is the basis for the discordance in these results?

Previous studies have indicated that pure MuSC culture is a powerful model for studying self-renewal (Abou-Khalil, Le Grand et al., 2009, Yin, Price et al., 2013, Zismanov, Chichkov et al., 2016). In our conditions, more than 99% of MuSCs are activated or are cycling 6h after plating, at the time of switch to differentiation medium (*i.e.* at time of the starting of the experiments, Figure S1B, panel “activation”). Then, analysis of self-renewal is performed after MuSCs are induced to differentiate and quiescent cells (Pax7<sup>+</sup>Ki67/MyoD<sup>-</sup> nuclei) must originate from those 99% of activated cells.

Testing high concentration of glucose (25 mM) without pyruvate is not possible since this condition is toxic for MuSCs and induces death of the cells (data not shown). Therefore, media of HGP condition (25 mM glucose) has been supplemented with 1 mM pyruvate (DMEM, #11966-025 GIBCO) to prevent cell death. Even there is no significant statistical difference, our results indicate that the number of quiescent cells exhibited a tendency to increase in AMPK $\alpha$ 1<sup>-/-</sup> versus WT MuSCs in HGP condition (+46%, p<0.15, N=4 with a high variability between MuSC cultures originating from 4 mice).

Moreover, the media, which has been used in the vast majority of our experiments (DMEM-HAMF12, #31331-028, GIBCO), is quite different from the media used in HGP condition, notably regarding amino acid quantities (please see the table below for some examples). Even such low differences may trigger some differences in cell fate, as it has been recently shown for hematopoietic stem cell self-renewal, for which valine plays an essential role (Taya, Ota et al., 2016).

Thus, we assume that is not possible to compare MuSC fate in these two different culture medium.

mM	Glucose	Alanine	Leucine	Proline	Serine	Tryptophan	Valine
DMEM – HAM F12	17	0.05	0.45	0.15	0.25	0.44	0.45
DMEM	25		0.80		0.40	0.78	0.80

**11. Figure 5G- the effect of compound 991 on LDHA activity in MuSCs at the doses indicated should be determined.**

Contrary to the analysis of muscle fate, that requires about 30000 cells *per* condition (Figure 4G), measurement of LDH activity requires higher amounts of cells. For MPCs, we found that a minimum of 230 000 cells *per* condition was required, keeping in mind that this number using MuSCs does not guarantee to reach the sufficient quantity of proteins to perform the assay when using MuSCs instead of MPCs. To recover enough material, a minimum of 24 mice would be required (1 mouse providing about 160000 MuSCs after one week of amplification, 2 mice *per* condition are required x 4 conditions x 3 independent experiments). Therefore, we are not able to measure the effects of compound 991 on LDH activity in the same conditions that were used for the analysis of MuSC fate.

However, to address the referee's point, we performed an alternative assay and measured lactate concentration in media of MuSCs cultured with compound 991 for 48h, as LDH converts pyruvate into lactate. Compound 991, a potent and specific AMPK activator (Bultot, Jensen et al., 2016), triggered the decrease of lactate concentration only in the media of WT MuSCs. Please see Figures 4H and S4C and modifications in the text (Page 13, last paragraph).

**12. Figure 6B- A WT control should be included with similar sodium oxamate dosing.**

WT control with similar sodium oxamate concentrations has been added. Please see Figures S5C (quiescent MuSCs) and S5D (lactate concentration) and modifications in

the text (Page 14, first paragraph).

13. Evidence for a "return to quiescence" described in the Discussion section is lacking. To make this claim, one would have to label MuSCs as they become activated, and then trace them to determine whether there are differences in returning to a quiescent MuSC or differentiation. The text should be changed to reflect this.

14. Evidence that AMPK fosters self-renewal is also lacking as there are no cell tracing studies for self-renewal, only that there are increased Pax7<sup>+</sup> MuSCs that have a slightly higher uptake of EdU. The language should be changed, or Pax7<sup>+</sup> MuSCs should be tracked to assess their stemness and self-renewing capacity.

We assume that the referee's concern in points 13 and 14 relies on the level of activation of satellite cells in various models. It has been shown, by us and others, that myogenic cells fully activate as Pax7<sup>+</sup>/MyoD<sup>+</sup> cells in the 3 models used in the present study. Thus, in both models, the quiescent Pax7<sup>+</sup>/ki67MyoD<sup>-</sup> cells originate from previously activated cells, and this refers to self-renewal or return to quiescence.

Previous studies have indicated that pure MuSC culture is a powerful self-renewal model (Abou-Khalil et al., 2009, Yin et al., 2013, Zismanov et al., 2016). In our conditions, more than 99% of the MuSCs are activated or cycling 6h after plating, at the time of switch to differentiation medium (*i.e.* at time of the starting of the experiments, Figure S1B, panel "activation"). Then, analysis of self-renewal is performed after MuSCs are induced to differentiate and quiescent cells (Pax7<sup>+</sup>Ki67/MyoD<sup>-</sup> nuclei) originate from those 99% of activated cells. Our results indicate that the number of quiescent cells was greatly increased in AMPK $\alpha$ 1<sup>-/-</sup> versus WT MuSCs (+367%, p<0.05, Figures 1B and 1D).

The second *in vitro* model we used, the single myofibres isolated from muscles and cultured for 3 days (Figure 1E), offers the unique opportunity of a direct tracing of MuSC fate at the clonal level (Abou-Khalil et al., 2009, Le Grand, Grifone et al., 2012, Yin et al., 2013, Zismanov et al., 2016). Indeed, after myofiber isolation, 100% of Pax7<sup>+</sup> MuSCs are activated and rapidly start to express MyoD (Zammit, Golding et al., 2004).

Here again, after 3 days of culture, the cells that are Pax7<sup>+</sup>MyoD<sup>-</sup> originate from the activated cells. Their number was strongly increased in AMPK $\alpha$ 1<sup>-/-</sup> cells as compared with WT cells in both EDL and *Plantaris* muscles (+147%, p<0.05 and +175%, p<0,01, respectively) (Figure 1E).

Upon muscle injury *in vivo*, MuSCs become activated into transit amplifying cells and proliferate while expressing both Pax7 and MyoD. Then, MuSCs either i) enter into terminal myogenic differentiation (Pax7 down-regulation and MyoD up-regulation) for the large majority of the cells or ii) self-renew and return to quiescence (MyoD down-regulation and Pax7 up-regulation) for a small subset of cells (Yin et al., 2013). In the *in vivo* cardiotoxin model, it has been shown that more than 95% of satellite cells become activated and do enter into the cell cycle 48 hours after injury (Rocheteau, Gayraud-Morel et al., 2012). Thus, the cells that are labelled as Pax7<sup>+</sup> Ki67/MyoD<sup>-</sup> at 28 days after muscle regeneration do originate from those activated cells and represent self-renewed cells (Figure 1G). Of note, we have checked that 100% of TA muscle is damaged after CTX injury in our experiments (data not shown), suggesting that all MuSCs of TA become activated after CTX injury. 28 days after injury, the percentage among MuSCs as well as the total number of quiescent Pax7<sup>+</sup>Ki67/MyoD<sup>-</sup> MuSCs were remarkably increased in Pax7- $\alpha$ 1<sup>-/-</sup> muscles as compared with the control muscles (18%, p<0.05 and 27%, p<0.05, respectively; Figures 1G-I).



## References

- Abou-Khalil R, Le Grand F, Chazaud B (2013) Human and murine skeletal muscle reserve cells. *Methods Mol Biol* 1035: 165-77
- Abou-Khalil R, Le Grand F, Pallafacchina G, Valable S, Authier FJ, Rudnicki MA, Gherardi RK, Germain S, Chretien F, Sotiropoulos A, Lafuste P, Montarras D, Chazaud B (2009) Autocrine and paracrine angiopoietin 1/Tie-2 signaling promotes muscle satellite cell self-renewal. *Cell stem cell* 5: 298-309
- Bultot L, Jensen TE, Lai YC, Madsen AL, Collodet C, Kviklyte S, Deak M, Yavari A, Foretz M, Ghaffari S, Bellahcene M, Ashrafian H, Rider MH, Richter EA, Sakamoto K (2016) Benzimidazole derivative small-molecule 991 enhances AMPK activity and glucose uptake induced by AICAR or contraction in skeletal muscle. *American journal of physiology* 311: E706-E719
- Charles JP, Cappellari O, Spence AJ, Hutchinson JR, Wells DJ (2016) Musculoskeletal Geometry, Muscle Architecture and Functional Specialisations of the Mouse Hindlimb. *PLoS One* 11: e0147669
- Dayton TL, Jacks T, Vander Heiden MG (2016) PKM2, cancer metabolism, and the road ahead. *EMBO Rep* 17: 1721-1730
- Fu X, Zhu MJ, Dodson MV, Du M (2015) AMP-activated Protein Kinase Stimulates Warburg-Like Glycolysis and Activation of Satellite Cells during Muscle Regeneration. *The Journal of biological chemistry*
- Garnier A, Fortin D, Delomenie C, Momken I, Veksler V, Ventura-Clapier R (2003) Depressed mitochondrial transcription factors and oxidative capacity in rat failing cardiac and skeletal muscles. *The Journal of physiology* 551: 491-501
- Kristensen JM, Skov V, Petersson SJ, Ortenblad N, Wojtaszewski JF, Beck-Nielsen H, Hojlund K (2014) A PGC-1alpha- and muscle fibre type-related decrease in markers of mitochondrial oxidative metabolism in skeletal muscle of humans with inherited insulin resistance. *Diabetologia* 57: 1006-15
- Latil M, Rocheteau P, Chatre L, Sanulli S, Memet S, Ricchetti M, Tajbakhsh S, Chretien F (2012) Skeletal muscle stem cells adopt a dormant cell state post mortem and retain regenerative capacity. *Nat Commun* 3: 903
- Le Grand F, Grifone R, Mourikis P, Houbron C, Gigaud C, Pujol J, Maillet M, Pages G, Rudnicki M, Tajbakhsh S, Maire P (2012) Six1 regulates stem cell repair potential and self-renewal during skeletal muscle regeneration. *The Journal of cell biology* 198: 815-32
- Leick L, Lyngby SS, Wojtaszewski JF, Pilegaard H (2010) PGC-1alpha is required for training-induced prevention of age-associated decline in mitochondrial enzymes in mouse skeletal muscle. *Exp Gerontol* 45: 336-42
- Lepper C, Conway SJ, Fan CM (2009) Adult satellite cells and embryonic muscle progenitors have distinct genetic requirements. *Nature* 460: 627-31
- Miller RA, Chu Q, Le Lay J, Scherer PE, Ahima RS, Kaestner KH, Foretz M, Viollet B, Birnbaum MJ (2011) Adiponectin suppresses gluconeogenic gene expression in mouse hepatocytes independent of LKB1-AMPK signaling. *J Clin Invest* 121: 2518-28
- Mounier R, Theret M, Arnold L, Cuvellier S, Bultot L, Goransson O, Sanz N, Ferry A, Sakamoto K, Foretz M, Viollet B, Chazaud B (2013) AMPKalpha1 Regulates Macrophage Skewing at the Time of Resolution of Inflammation during Skeletal Muscle Regeneration. *Cell metabolism* 18: 251-64

- Nakada D, Saunders TL, Morrison SJ (2010) Lkb1 regulates cell cycle and energy metabolism in haematopoietic stem cells. *Nature* 468: 653-8
- Nichenko AS, Southern WM, Atuan M, Luan J, Peissig KB, Foltz SJ, Beedle AM, Warren GL, Call JA (2016) Mitochondrial maintenance via autophagy contributes to functional skeletal muscle regeneration and remodeling. *Am J Physiol Cell Physiol* 311: C190-200
- Olguin HC, Olwin BB (2004) Pax-7 up-regulation inhibits myogenesis and cell cycle progression in satellite cells: a potential mechanism for self-renewal. *Dev Biol* 275: 375-88
- Rocheteau P, Gayraud-Morel B, Siegl-Cachedenier I, Blasco MA, Tajbakhsh S (2012) A subpopulation of adult skeletal muscle stem cells retains all template DNA strands after cell division. *Cell* 148: 112-25
- Ryall JG, Dell'Orso S, Derfoul A, Juan A, Zare H, Feng X, Clermont D, Koulis M, Gutierrez-Cruz G, Fulco M, Sartorelli V (2015) The NAD(+)-dependent SIRT1 deacetylase translates a metabolic switch into regulatory epigenetics in skeletal muscle stem cells. *Cell stem cell* 16: 171-83
- Taya Y, Ota Y, Wilkinson AC, Kanazawa A, Watarai H, Kasai M, Nakauchi H, Yamazaki S (2016) Depleting dietary valine permits nonmyeloablative mouse hematopoietic stem cell transplantation. *Science* 354: 1152-1155
- TeSlaa T, Teitell MA (2014) Techniques to monitor glycolysis. *Methods Enzymol* 542: 91-114
- Yin H, Price F, Rudnicki MA (2013) Satellite cells and the muscle stem cell niche. *Physiol Rev* 93: 23-67
- Zammit PS, Golding JP, Nagata Y, Hudon V, Partridge TA, Beauchamp JR (2004) Muscle satellite cells adopt divergent fates: a mechanism for self-renewal? *The Journal of cell biology* 166: 347-57
- Zhang H, Ryu D, Wu Y, Gariani K, Wang X, Luan P, D'Amico D, Ropelle ER, Lutolf MP, Aebbersold R, Schoonjans K, Menzies KJ, Auwerx J (2016) NAD(+) repletion improves mitochondrial and stem cell function and enhances life span in mice. *Science* 352: 1436-43
- Zismanov V, Chichkov V, Colangelo V, Jamet S, Wang S, Syme A, Koromilas AE, Crist C (2016) Phosphorylation of eIF2alpha Is a Translational Control Mechanism Regulating Muscle Stem Cell Quiescence and Self-Renewal. *Cell stem cell* 18: 79-90

2nd Editorial Decision

07 April 2017

Thank you for submitting your revised manuscript for our consideration. Your manuscript has now been seen once more by the original referees (see comments below), and I am happy to inform you that they are both broadly in favor of publication, pending satisfactory minor revision.

I would therefore like to ask you to address referee #2's comment and to provide a final version of your manuscript.

-----  
REFEREE REPORTS

Referee #1:

The authors addressed my concerns. The revised version is improved.

Referee #2:

The authors provided an improved revised manuscript that addressed concerns raised during review.

One comment: The authors use citrate synthase (CS) activity and TOM22 protein expression as measures for mitochondrial mass. They report a reduction in CS activity in MPCs lacking AMPK $\alpha$ 1. They also report that some MPCs are negative for TOM22 (-11%,  $p < 0.03$ , new Figure S3G) with AMPK $\alpha$ 1 knockout. This seems odd since TOM22 is the central receptor for mitochondrial protein import and imported proteins in TOM22 negative cells are inactive due to misfolding. Are the authors saying that these MPCs express TOM22 below the level of detection for their antibodies? Or that these MPCs lack mitochondria?

2nd Revision - authors' response

18 April 2017

Regarding referee #2's comment, our results regarding MPCs that are negative for TOM22, suggested that these MPCs express TOM22 below the level of detection for TOM22 antibody in these conditions.

3rd Editorial Decision

20 April 2017

Thank you for submitting your revised manuscript to us. I am happy to inform you that your manuscript has been accepted for publication in The EMBO Journal.

**YOU MUST COMPLETE ALL CELLS WITH A PINK BACKGROUND ↓**

PLEASE NOTE THAT THIS CHECKLIST WILL BE PUBLISHED ALONGSIDE YOUR PAPER

Corresponding Author Name: Rémi Mounier

Journal Submitted to: EMBO Journal

Manuscript Number: EMBOJ-2016-95273R

### Reporting Checklist For Life Sciences Articles (Rev. July 2015)

This checklist is used to ensure good reporting standards and to improve the reproducibility of published results. These guidelines are consistent with the Principles and Guidelines for Reporting Preclinical Research issued by the NIH in 2014. Please follow the journal's authorship guidelines in preparing your manuscript.

#### A- Figures

##### 1. Data

The data shown in figures should satisfy the following conditions:

- the data were obtained and processed according to the field's best practice and are presented to reflect the results of the experiments in an accurate and unbiased manner.
- figure panels include only data points, measurements or observations that can be compared to each other in a scientifically meaningful way.
- graphs include clearly labeled error bars for independent experiments and sample sizes. Unless justified, error bars should not be shown for technical replicates.
- if  $n < 5$ , the individual data points from each experiment should be plotted and any statistical test employed should be justified
- Source Data should be included to report the data underlying graphs. Please follow the guidelines set out in the author ship guidelines on Data Presentation.

##### 2. Captions

Each figure caption should contain the following information, for each panel where they are relevant:

- a specification of the experimental system investigated (eg cell line, species name).
- the assay(s) and method(s) used to carry out the reported observations and measurements
- an explicit mention of the biological and chemical entity(ies) that are being measured.
- an explicit mention of the biological and chemical entity(ies) that are altered/varied/perturbed in a controlled manner.
- the exact sample size (n) for each experimental group/condition, given as a number, not a range;
- a description of the sample collection allowing the reader to understand whether the samples represent technical or biological replicates (including how many animals, litters, cultures, etc.).
- a statement of how many times the experiment shown was independently replicated in the laboratory.
- definitions of statistical methods and measures:
  - common tests, such as t-test (please specify whether paired vs. unpaired), simple  $\chi^2$  tests, Wilcoxon and Mann-Whitney tests, can be unambiguously identified by name only, but more complex techniques should be described in the methods section;
  - are tests one-sided or two-sided?
  - are there adjustments for multiple comparisons?
  - exact statistical test results, e.g., P values = x but not P values < x;
  - definition of 'center values' as median or average;
  - definition of error bars as s.d. or s.e.m.

Any descriptions too long for the figure legend should be included in the methods section and/or with the source data.

Please ensure that the answers to the following questions are reported in the manuscript itself. We encourage you to include a specific subsection in the methods section for statistics, reagents, animal models and human subjects.

In the pink boxes below, provide the page number(s) of the manuscript draft or figure legend(s) where the information can be located. Every question should be answered. If the question is not relevant to your research, please write NA (non applicable).

#### B- Statistics and general methods

Please fill out these boxes ↓ (Do not worry if you cannot see all your text once you press return)

1.a. How was the sample size chosen to ensure adequate power to detect a pre-specified effect size?	NA
1.b. For animal studies, include a statement about sample size estimate even if no statistical methods were used.	Pages 20-28 and 31-38
2. Describe inclusion/exclusion criteria if samples or animals were excluded from the analysis. Were the criteria pre-established?	Pages 20-28 and 31-38
3. Were any steps taken to minimize the effects of subjective bias when allocating animals/samples to treatment (e.g. randomization procedure)? If yes, please describe.	Pages 20-28 and 31-38
For animal studies, include a statement about randomization even if no randomization was used.	Pages 20-28 and 31-38
4.a. Were any steps taken to minimize the effects of subjective bias during group allocation or/and when assessing results (e.g. blinding of the investigator)? If yes please describe.	Pages 20-28 and 31-38
4.b. For animal studies, include a statement about blinding even if no blinding was done	Pages 20-28 and 31-38
5. For every figure, are statistical tests justified as appropriate?	Pages 31-38
Do the data meet the assumptions of the tests (e.g., normal distribution)? Describe any methods used to assess it.	Pages 20-28 and 31-38
Is there an estimate of variation within each group of data?	Pages 20-28 and 31-38
Is the variance similar between the groups that are being statistically compared?	Pages 20-28 and 31-38

#### C- Reagents

#### USEFUL LINKS FOR COMPLETING THIS FORM

<http://www.antibodypedia.com>  
<http://1degreebio.org>  
<http://www.equator-network.org/reporting-guidelines/improving-bioscience-research-repo>

<http://grants.nih.gov/grants/olaw/olaw.htm>  
<http://www.mrc.ac.uk/Ourresearch/Ethicsresearchguidance/Useofanimals/index.htm>  
<http://ClinicalTrials.gov>  
<http://www.consort-statement.org>  
<http://www.consort-statement.org/checklists/view/32-consort/66-title>

<http://www.equator-network.org/reporting-guidelines/reporting-recommendations-for-tun>

<http://datadryad.org>

<http://figshare.com>

<http://www.ncbi.nlm.nih.gov/gap>

<http://www.ebi.ac.uk/ega>

<http://biomodels.net/>

<http://biomodels.net/miriam/>  
<http://jil.biochem.sun.ac.za>  
[http://oba.od.nih.gov/biosecurity/biosecurity\\_documents.html](http://oba.od.nih.gov/biosecurity/biosecurity_documents.html)  
<http://www.selectagents.gov/>

6. To show that antibodies were profiled for use in the system under study (assay and species), provide a citation, catalog number and/or clone number, supplementary information or reference to an antibody validation profile. e.g., Antibodypedia (see link list at top right), 1DegreeBio (see link list at top right).	Pages 20-28
7. Identify the source of cell lines and report if they were recently authenticated (e.g., by STR profiling) and tested for mycoplasma contamination.	NA

\* for all hyperlinks, please see the table at the top right of the document

#### D- Animal Models

8. Report species, strain, gender, age of animals and genetic modification status where applicable. Please detail housing and husbandry conditions and the source of animals.	Page 20
9. For experiments involving live vertebrates, include a statement of compliance with ethical regulations and identify the committee(s) approving the experiments.	Page 20
10. We recommend consulting the ARRIVE guidelines (see link list at top right) (PLoS Biol. 8(6), e1000412, 2010) to ensure that other relevant aspects of animal studies are adequately reported. See author guidelines, under 'Reporting Guidelines'. See also: NIH (see link list at top right) and MRC (see link list at top right) recommendations. Please confirm compliance.	Page 20

#### E- Human Subjects

11. Identify the committee(s) approving the study protocol.	NA
12. Include a statement confirming that informed consent was obtained from all subjects and that the experiments conformed to the principles set out in the WMA Declaration of Helsinki and the Department of Health and Human Services Belmont Report.	NA
13. For publication of patient photos, include a statement confirming that consent to publish was obtained.	NA
14. Report any restrictions on the availability (and/or on the use) of human data or samples.	NA
15. Report the clinical trial registration number (at ClinicalTrials.gov or equivalent), where applicable.	NA
16. For phase II and III randomized controlled trials, please refer to the CONSORT flow diagram (see link list at top right) and submit the CONSORT checklist (see link list at top right) with your submission. See author guidelines, under 'Reporting Guidelines'. Please confirm you have submitted this list.	NA
17. For tumor marker prognostic studies, we recommend that you follow the REMARK reporting guidelines (see link list at top right). See author guidelines, under 'Reporting Guidelines'. Please confirm you have followed these guidelines.	NA

#### F- Data Accessibility

18. Provide accession codes for deposited data. See author guidelines, under 'Data Deposition'. Data deposition in a public repository is mandatory for: a. Protein, DNA and RNA sequences b. Macromolecular structures c. Crystallographic data for small molecules d. Functional genomics data e. Proteomics and molecular interactions	NA
19. Deposition is strongly recommended for any datasets that are central and integral to the study; please consider the Journal's data policy. If no structured public repository exists for a given data type, we encourage the provision of datasets in the manuscript as a Supplementary Document (see author guidelines under 'Expanded View' or in unstructured repositories such as Dryad (see link list at top right) or Figshare (see link list at top right).	NA
20. Access to human clinical and genomic datasets should be provided with as few restrictions as possible while respecting ethical obligations to the patients and relevant medical and legal issues. If practically possible and compatible with the individual consent agreement used in the study, such data should be deposited in one of the major public access-controlled repositories such as dbGAP (see link list at top right) or EGA (see link list at top right).	NA
21. As far as possible, primary and referenced data should be formally cited in a Data Availability section. Please state whether you have included this section.  Examples: <b>Primary Data</b> Wetmore KM, Deuschbauer AM, Price MN, Arkin AP (2012). Comparison of gene expression and mutant fitness in <i>Shewanella oneidensis</i> MR-1. Gene Expression Omnibus GSE39462 <b>Referenced Data</b> Huang J, Brown AF, Lei M (2012). Crystal structure of the TRBD domain of TERT and the CR4/5 of TR. Protein Data Bank 4O26 AP-MS analysis of human histone deacetylase interactions in CEM-T cells (2013). PRIDE PXD000208	NA
22. Computational models that are central and integral to a study should be shared without restrictions and provided in a machine-readable form. The relevant accession numbers or links should be provided. When possible, standardized format (SBML, CellML) should be used instead of scripts (e.g. MATLAB). Authors are strongly encouraged to follow the MIRIAM guidelines (see link list at top right) and deposit their model in a public database such as Biomodels (see link list at top right) or JWS Online (see link list at top right). If computer source code is provided with the paper, it should be deposited in a public repository or included in supplementary information.	NA

#### G- Dual use research of concern

23. Could your study fall under dual use research restrictions? Please check biosecurity documents (see link list at top right) and list of select agents and toxins (APHIS/CDC) (see link list at top right). According to our biosecurity guidelines, provide a statement only if it could.	NA
---	----